

- NOTES:
 1. CONNECTOR:
 MATES WITH: PT06A-10-6S (SR)
 2. UNITS: [mm]
 INCH

REVISIONS					
ZONE	REV	DESCRIPTION	DATE	ECO	DRFTSMN
	A	RELEASE TO PRODUCTION	06/09/2016	27842	R.B.
	B	ADDED SIDE VIEWS ; MOVED ISO VIEWS; ADDED RAILSTAR LABEL	1/22/2024	31175	G.R.

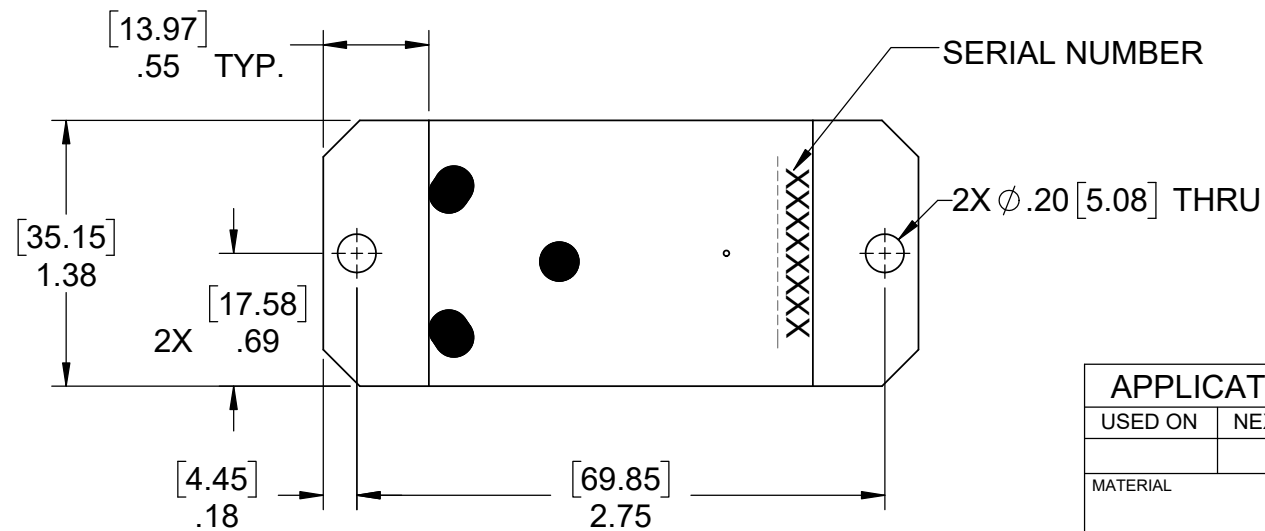
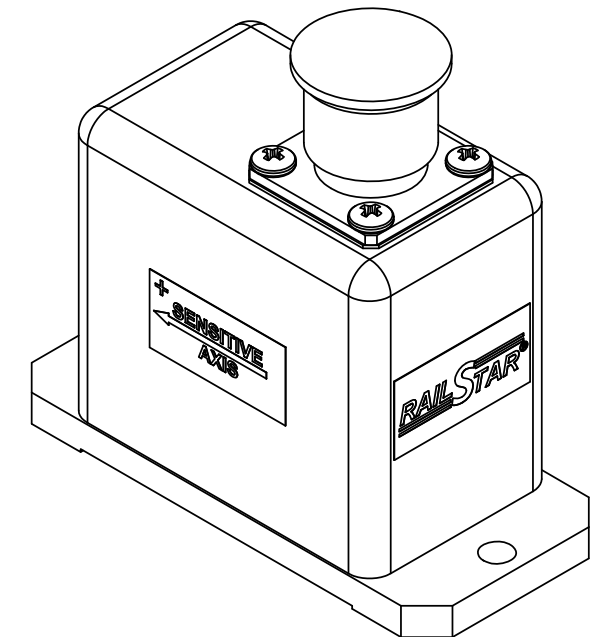
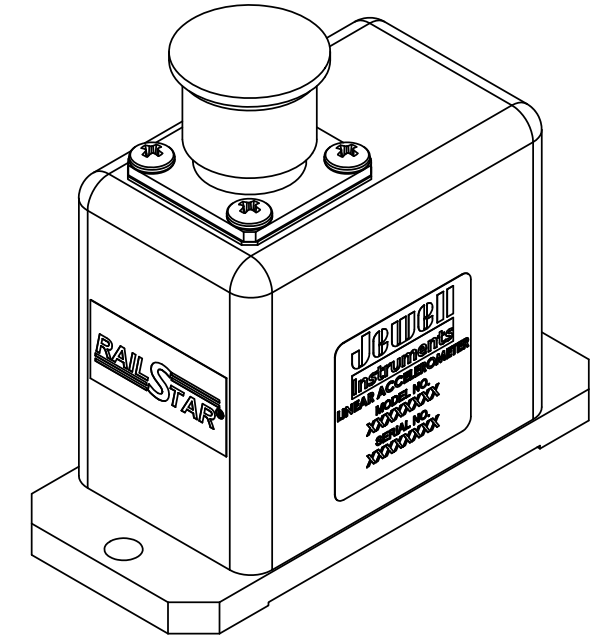
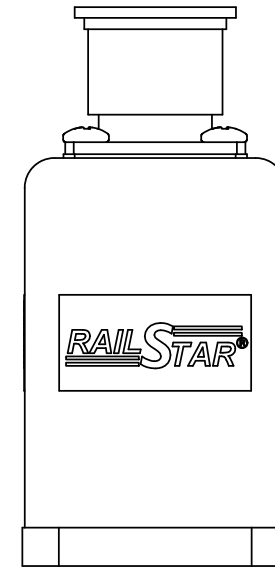
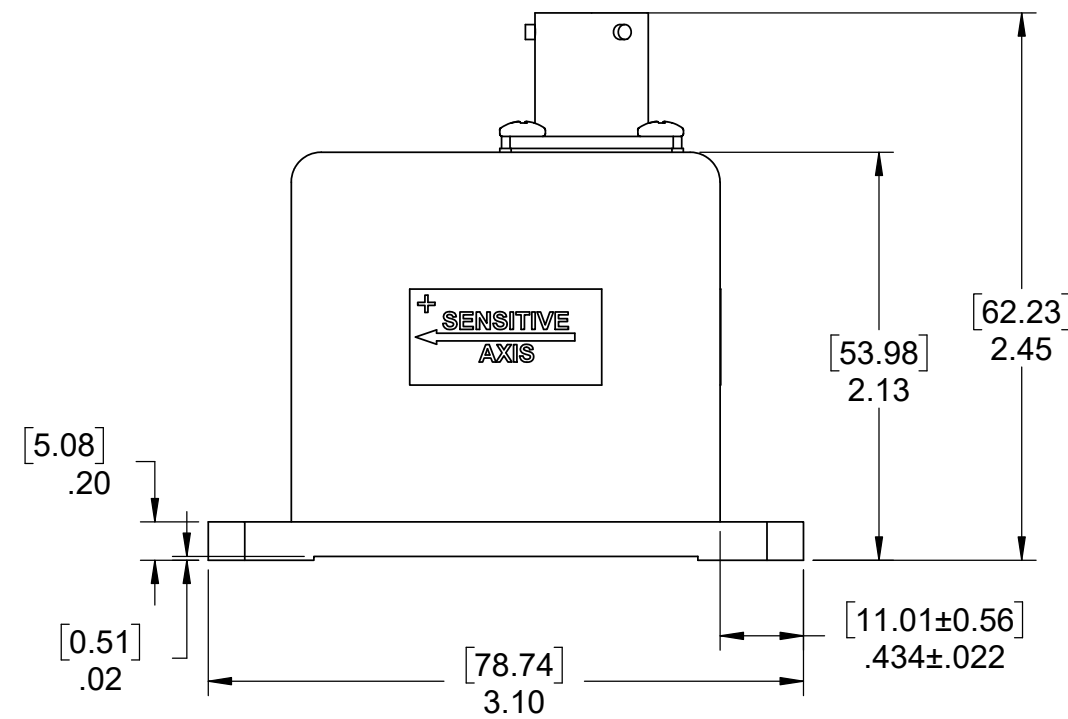
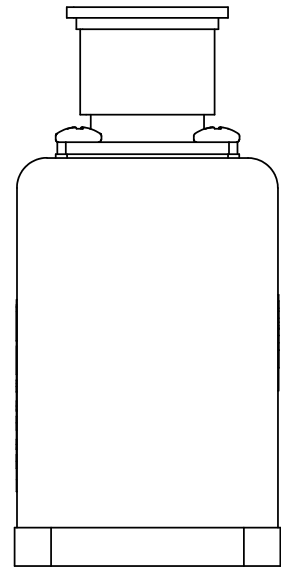
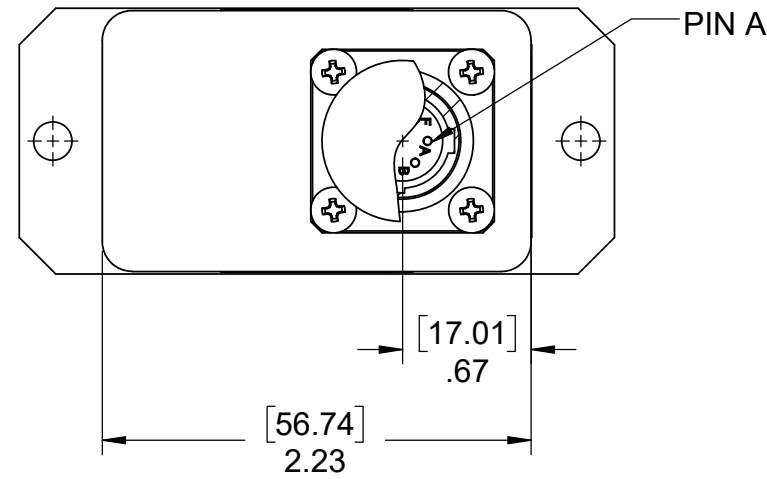

PIN	FUNCTION
	DUAL SUPPLY
A	+ VDC
B	PWR / SIG COM
C	- VDC
D	SIG OUT
E	N/C
F	N/C

APPLICATION		DIMENSIONS ARE IN INCHES AND APPLY TO PART BEFORE FINISHING	
USED ON	NEXT ASSY	TOLERANCE UNLESS SPECIFIED	
		TWO PLACE DECIMALS (.00) ± .01	
		THREE PLACE DECIMALS (.000) ± .005	
		ANGLES ± 1°	
		RAW MATL - COMMERCIAL STANDARD	
MATERIAL		DRAWN	DATE
		R.B.	06/09/2016
		CHECKER	DATE
FINISH		APPROVED	DATE



MANCHESTER, NH
 TRIPLETT MODUTEC A&M EMICO

PROPRIETARY NOTICE
 THIS DRAWING IS THE PROPERTY OF JEWELL INSTRUMENTS, LLC. NEITHER THIS DOCUMENT NOR THE DATA CONTAINED HEREIN SHALL BE DISCLOSED, REPRODUCED IN WHOLE OR IN PART WITHOUT THE WRITTEN AUTHORIZATION OF JEWELL INSTRUMENTS, LLC. NO RIGHT IS GRANTED TO DISCLOSE OR SO USE ANY INFORMATION CONTAINED HEREIN. ALL RIGHTS RESERVED.

TITLE		
LCF 501-R OUTLINE DRAWING		
DRAWING NO.	REV	
OD03550584-000	B	
SCALE	CAGE CODE	SHEET 1 OF 1
1:1	33005	