

USER'S MANUAL
MINIATURE TILT SENSOR

850 Perimeter Road



Manchester, NH 03103 USA

Tel (603) 669-6400

Fax (603) 622-2690

sales@jewellinstruments.com

www.jewellinstruments.com

Copyright ©2013 by Jewell Instruments LLC. All rights reserved.

WARNING:

**NEVER APPLY DC CURRENT THROUGH THE TILT TRANSDUCERS!
NEVER USE AN OHMMETER TO TEST THE TRANSDUCERS!
DOING SO WILL CAUSE PERMANENT DAMAGE THAT IS NOT
COVERED BY THE WARRANTY.**

MINIATURE TILT SENSOR

TABLE OF CONTENTS

| | |
|--|----|
| 1 - INTRODUCTION..... | 3 |
| 2 - MECHANICAL DESCRIPTION..... | 3 |
| 3 - ELECTRONIC SIGNAL CONDITIONING..... | 3 |
| 4 - GENERAL SPECIFICATIONS..... | 5 |
| 5 - ROUTINE MAINTENANCE..... | 6 |
| 6 - TROUBLESHOOTING | 6 |
| APPENDIX A - WARRANTY AND ASSISTANCE | 14 |
| APPENDIX B - CUSTOM SPECIFICATIONS | 15 |
| For your Miniature Tilt Sensor | 15 |
| For your Equipment | 16 |
| APPENDIX C - LM35 TEMP. SENSOR..... | 17 |
| APPENDIX D - REVISIONS | 18 |

LIST OF TABLES:

| | |
|---|---|
| 1 - Physical Characteristics: Series 755 High-Gain Miniature Tilt Sensors | 7 |
| 2 - Physical Characteristics: Series 756 Mid-Range Miniature Tilt Sensors | 7 |

LIST OF FIGURES:

| | |
|---|----|
| Figure 1: Model 781 Signal Conditioning Unit w/Model 755-1172 Miniature Tilt Sensor | 8 |
| Figure 2: 755 Series High Gain, & 756 Series Mid-Range Miniature Tilt Sensors | 9 |
| Figure 3: Mounting Hole Patterns for Miniature Tilt Sensors | 10 |
| Figure 4: Electrolevel Physical Characteristics | 11 |
| Figure 5: Electrolevel Electrical Characteristics | 11 |
| Figure 6: Basic Signal Conditioning: One Electrolytic Sensor | 12 |
| Figure 7: Basic Signal Conditioning: Two Electrolytic Sensors | 13 |

1 - INTRODUCTION

Congratulations! You have purchased a Jewell Instruments Miniature Tilt Sensor - the most precise and repeatable commercial sensor for measuring gravity-referenced angular movements.

Your Miniature Tilt Sensor contains either one or two electrolytic tilt transducers, one for each orthogonal axis of rotation. Series 755 sensors contain high-gain (Type A) transducers that resolve angular changes smaller than 0.1 microradian over ± 1 degree of arc. Series 756 sensors incorporate mid-range (Type B) transducers that resolve 1 microradian over ± 10 degrees. The type of transducers in your Miniature Tilt Sensor is shown in Appendix B.

We recommend that your sensor be operated with signal conditioning electronics supplied by Jewell Instruments LLC (Figure 1). It also may be operated using third-party electronics that supply appropriate transducer excitation and signal conditioning of transducer output. Signal conditioning is discussed in Section 3.0 of this manual.

Miniature Tilt Sensors are part of a family of precision instrumentation from Jewell Instruments LLC. Included are 800 Series Uniaxial Tiltmeters, 700 Series Biaxial Tiltmeters, 500 Series Geodetic Tiltmeters, and the new Electrolevel monitoring system. Jewell Instruments' instrumentation is used worldwide for measuring the behavior of dams, power plants, machinery, mines, bridges, buildings, tunnels, tanks, retaining walls, wells, landslides, volcanoes, and other natural and manmade structures. Low-cost, automated data acquisition and alarm systems are also part of Jewell Instruments' instrumentation family. Please contact the factory for more information on these products.

2 - MECHANICAL DESCRIPTION

Series 755 and 756 Miniature Tilt Sensors are supplied in five standard sensor housings (Figures 2 and 3). In addition, special housing shapes, sizes, and materials are available upon customer request.

Standard housings are made of anodized aluminum. Housings also are available in stainless steel, and invar for a small additional charge. The tilt transducers are potted into the housings with a special ceramic cement.

Sensor housings are either single or dual axis, as indicated in Tables 1 and 2. Temperature sensors are potted into several, but not all of the standard housings (Tables 1 and 2). Mounting holes allow for easy attachment to almost any flat surface.

3 - ELECTRONIC SIGNAL CONDITIONING

Your Miniature Tilt Sensor uses either one or two electrolytic tilt transducers as the sensing elements. These transducers are essentially electronic spirit levels (electrolevels). They consist of a fluid-filled glass vial with three electrodes mounted inside, in contact with the conductive fluid (Figure 4). The transducers operate on the fundamental principle that a bubble, suspended in a liquid-filled case, is always bisected by the vertical gravity vector. As the transducer tilts, the vial moves around the bubble, alternately covering and uncovering the two excitation electrodes.

When a constant AC voltage is applied across the two excitation electrodes, the AC output measured at the central pick-up electrode changes in linear proportion to the tilt angle. In other words, the transducer behaves as an AC variable resistor (potentiometer). DC excitation **may not** be used to operate the transducers. With suitable signal conditioning, the transducers in your Miniature Tilt Sensor will achieve the performance specifications listed in the "Specifications" section of this manual.

For signal conditioning, we recommend use of one of the following Jewell Instrument signal conditioning units. Jewell provides calibration data for sensor(s) and signal conditioning unit(s) that are purchased together. Calibration information is found in the user's manual of the signal condition units.

Model 755 Readout/Electronics Unit: Powers one biaxial tilt sensor, or two uniaxial sensors. Conditions the output signals, and displays the conditioned outputs on LCD displays. Coaxial connectors supply analog DC signals for logging by external recorders.

Model 781 Signal Conditioning Unit: Terminal strips on the unit provide connections for the tilt sensor wires, an external DC power supply (± 12 volts), and analog DC output signals. Operates one biaxial tilt sensor, or two uniaxial sensors. Digital displays are not provided with this unit.

Model 786 Signal Conditioning Unit: This rack-mount unit operates up to eight biaxial tilt sensors or 16 uniaxial sensors, and is powered by 110 or 220 VAC. Sensor connections and analog DC output connections are made at connectors on the back panel. Digital displays are not provided with this unit.

Model 83162 board level Signal Conditioner: This unit is a fully stuffed and functional printed circuit board that operates two tilt transducers, and one temperature sensor simultaneously. Outputs are single-ended and differential voltages. Power requirements are ± 12 volts DC. The Model 83162 is intended for users who need to install the signal conditioner in their own mechanical packaging.

"IRIS" SC Digital Signal Conditioning Card: "IRIS" SC provides signal conditioning and serial data output for all of our Miniature Tilt Sensors. Use it with up to two uniaxial sensors, or any biaxial sensor. It has a 16-bit A/D converter, 540K of onboard FLASH memory, a real-time clock, and it also measures temperature. Its powerful firmware commands include low-pass filtering, autozero, sampling frequency selection, RS232 or RS422 selection, and onboard data storage. Other commands enable you to select among data formats, including formats compatible with popular GPS receivers. "IRIS" SC also operates as a tilt switch and controller. This product is a perfect choice for applications that require digital data streams or onboard recording of tilt measurements.

Model 84800 Single-Channel Signal Conditioner: This signal conditioning card is a compact electronic circuit that provides excitation and signal conditioning for any electrolytic tilt sensor and one LM-35 temperature sensor. A wide input voltage range, reverse polarity protection and transient surge protection are advantages of this circuit. Its 2-pole Butterworth low-pass filter can be tuned to your special requirements. Model 84800 will drive its analog voltage output signals over cable lengths longer than 300m. Four mounting holes allow easy packaging in OEM and end-user assemblies. This circuit is an excellent match for our high-precision 755 and 756 Series sensors and for all of our other miniature Tilt Sensors.

Figure 5 shows a basic electrical circuit for operating one electrolytic tilt transducer. Figure 6 shows a basic circuit for operating two transducers simultaneously, as in the case of a biaxial sensor. Please note that these basic circuits may not achieve the performance specifications listed in Section 4.0 of this manual. Nor are they likely to provide the ease of use available from the signal conditioning units listed above.

WARNING:

**NEVER APPLY DC CURRENT THROUGH THE TILT TRANSDUCERS!
NEVER USE AN OHMMETER TO TEST THE TRANSDUCERS!
DOING SO WILL CAUSE PERMANENT DAMAGE THAT IS NOT
COVERED BY THE WARRANTY.**

4 - GENERAL SPECIFICATIONS

Typical physical and performance specifications for Miniature Tilt Sensors are listed below. Resolution (sensitivity), repeatability and linearity specifications were measured using Jewell Instruments signal conditioning electronics.

| | |
|--|---|
| TOTAL RANGE | Series 755: ± 1 arc degrees Series 756: ± 10 arc degrees |
| RESOLUTION | Series 755: 0.1 microradian (0.02 arc second) or better Series 756: 1 microradian (0.2 arc second) or better |
| REPEATABILITY | Series 755: 1 microradian (0.2 arc second) Series 756: 5 microradians (1 arc second) |
| LINEARITY | Series 755: within 0.1 arc minute at an angle of ± 10 arc minutes, within 0.5 arc minute at an angle of ± 20 arc minutes; Series 756: within 0.03 degrees at an angle of ± 3 degrees. within 0.17 degrees at an angle of ± 6 degree; |
| SCALE FACTOR @ 20°C | Series 755: 7.2 mV/arc minute/volt excitation $\pm 20\%$ Series 756: 34 mV/arc degree/volt excitation $\pm 20\%$ |
| CHANGE IN SCALE FACTOR w/TEMPERATURE CHANGE | Series 755: -0.05% per °C Series 756: -0.05% per °C |
| POWER REQUIREMENTS | AC excitation @ 3-5 volts peak-to-peak, 400 Hz to 10 kHz Typically provided by Jewell Instruments signal conditioning electronics |
| TEMPERATURE RANGE | -40°C [-40°F] TO +80°C [176°F] operational -50°C [-58°F] TO +100°C [212°F] storage |
| HUMIDITY RANGE | 0 to 100%. <u>Standard sensors are not submersible.</u> |
| SIZE AND WEIGHT | See Tables 1 and 2. |
| MATERIALS | Standard Housings: Anodized 6061-T6 aluminum; stainless steel, invar, brass, ceramic and fiberglass housings are available on request. |

5 - ROUTINE MAINTENANCE

Keep your Miniature Tilt Sensor away from extremes of heat and cold. Extreme temperatures unnecessarily stress the transducers. Keep the sensor out of direct sun because heat build-up can cause high internal temperatures.

Unless it is designated as a submersible unit, keep your Miniature Tilt Sensor dry. The ceramic cement that pots the transducers in place is porous and will absorb water if wetted, possibly causing electrical noise, or even damage to the transducers.

6 - TROUBLESHOOTING

Your Miniature Tilt Sensor is a very simple system, consisting of four basic parts: transducers, potting cement, housing, and signal wires (three wires per transducer). Because of this simplicity, there are relatively few ways in which it can malfunction. Malfunctions are typically traceable to the signal conditioning electronics that are used to operate your tilt sensor.

If you are sure that your signal conditioner is working properly and you suspect a problem with the sensor, first check the following:

Wiring: Most problems are caused by a faulty wire or connection.

Broken transducer: Broken (cracked tilt transducers are quite rare but can occur. Symptoms of a broken transducer are no output change, or extremely small output change, when the sensor housing is rotated through its full angular range. Because the transducer is fully covered by potting cement, you will not be able to see a crack in the glass transducer vial. However, breakage is normally indicated by local discoloration of the cement, and a faint ethanol smell.

Transducer damaged by DC current: The tilt transducers in your sensor contain an electrolytic fluid. Passing DC current through the transducers causes plating of the electrolyte onto one or more of the internal electrodes, creating permanent damage. This type of damage is not covered by the warranty.

**NEVER APPLY DC CURRENT THROUGH THE TILT TRANSDUCERS!
NEVER USE AN OHMMETER TO TEST THE TRANSDUCERS!**

Apart from the checks outlined here, your Miniature Tilt Sensor is not field-serviceable. If you should encounter any problems, please contact Jewell Instruments LLC in Manchester, New Hampshire at telephone (603) 669-6400, or fax (603) 622-6290. A sales representative will be pleased to assist you.

TABLE 1**Physical Characteristics: Series 755 High-Gain Miniature Tilt Sensors**

| MODEL | CHANNELS | MOUNTING | DIMENSIONS | WEIGHT |
|-------|-----------------|---|--|---------------|
| -1129 | 2 tilt, 1 temp. | Horiz. surface or vert. tube; hole dia. = 0.18" (4.5 mm) | 1.98" dia. cylinder x .75" high (50.3 x 19.1 mm)_ | 4 oz. (114g) |
| -1326 | 2 tilt, 1 temp. | Horiz. surface or vert. tube; mounting hole dia. = 0.15" (3.9 mm) | 1.37" dia. cylinder x 1.25" high (34.8 x 31.8 mm)_ | 2.8 oz. (79g) |
| -1148 | 2 tilt, 1 temp. | Horiz. surface; mounting hole dia. = 0.20" (5.1 mm) | 2.12" x 3.00" x 0.74" (54.9 x 76.2 x 18.8 mm)_ | 7 oz. (200g) |
| -1150 | 2 tilt, 1 temp. | Horiz. or vert. surface; hole dia. = 0.18" (4.4 mm) | 1.62" x 2.00" x 1.00" (41.2 x 50.8 x 25.4 mm)_ | 5 oz. (142g) |
| -1172 | 1 tilt | Horiz. or vert. surface; hole dia. = 0.17" (4.3 mm) | 2.00" x 0.62" x 0.62" (50.8 x 15.7 x 15.7 mm)_ | 1.5 oz. (42g) |

NOTE: Vacuum-compatible elements do not include the temperature sensor.

TABLE 2**Physical Characteristics: Series 756 Mid-Range Miniature Tilt Sensors**

| MODEL | CHANNELS | MOUNTING | DIMENSIONS | WEIGHT |
|-------|-----------------|---|--|---------------|
| -1129 | 2 tilt, 1 temp. | Horiz. surface or vert. tube; hole dia. = 0.18" (4.5 mm) | 1.98" dia. cylinder x .75" high (50.3 x 19.1 mm)_ | 4 oz. (114g) |
| -1326 | 2 tilt, 1 temp. | Horiz. surface or vert. tube. mounting hole dia. = 0.15" (3.9 mm) | 1.37" dia. cylinder x 1.25" high (34.8 x 31.8 mm)_ | 2.8 oz. (79g) |
| -1148 | 2 tilt, 1 temp. | Horiz. surface; mounting hole dia. = 0.20" (5.1 mm) | 2.12" x 3.00" x 0.74" (54.9 x 76.2 x 18.8 mm)_ | 7 oz. (200g) |
| -1150 | 2 tilt, 1 temp. | Horiz. or vert. surface; hole dia. = 0.18" (4.4 mm) | 1.62" x 2.00" x 1.00" (41.2 x 50.8 x 25.4 mm)_ | 5 oz. (142g) |
| -1172 | 1 tilt | Horiz. or vert. surface; hole dia. = 0.17" (4.3 mm) | 2.00" x 0.62" x 0.62" (50.8 x 15.7 x 15.7 mm)_ | 1.5 oz. (42g) |

NOTE: Vacuum-compatible elements do not include the temperature sensor.



FIGURE 1

Model 781 Signal Conditioning Unit with Model 755-1172 Miniature Tilt Sensor.

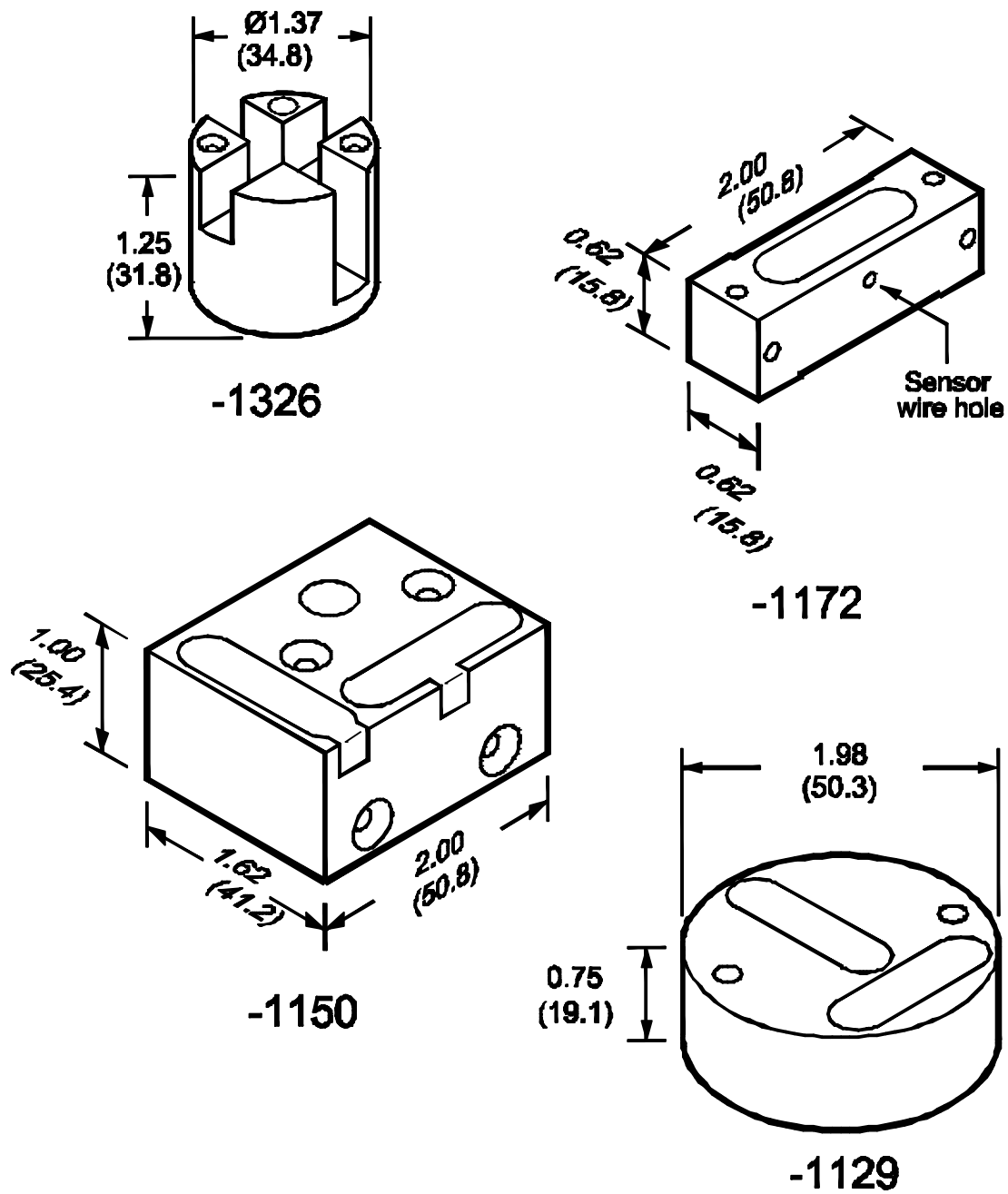

NOT TO SCALE
Dimensions in inches (mm)
 (For mounting hole information see next page)

FIGURE 2

Model 755 Series (High-Gain), and Model 756 (Mid-Range) Miniature Tilt Sensors

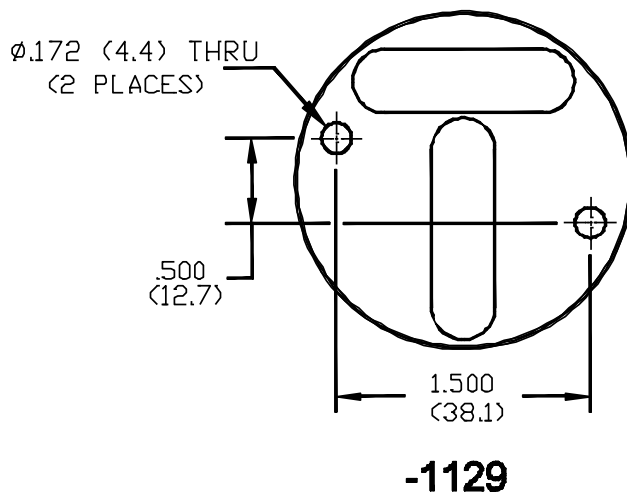
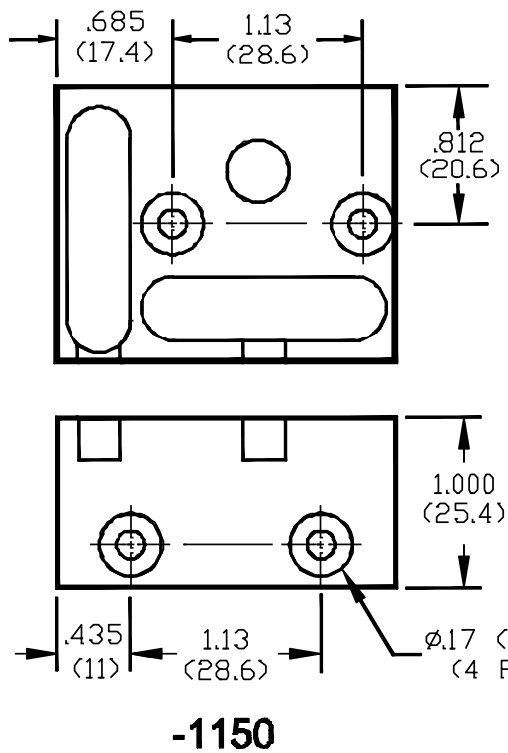
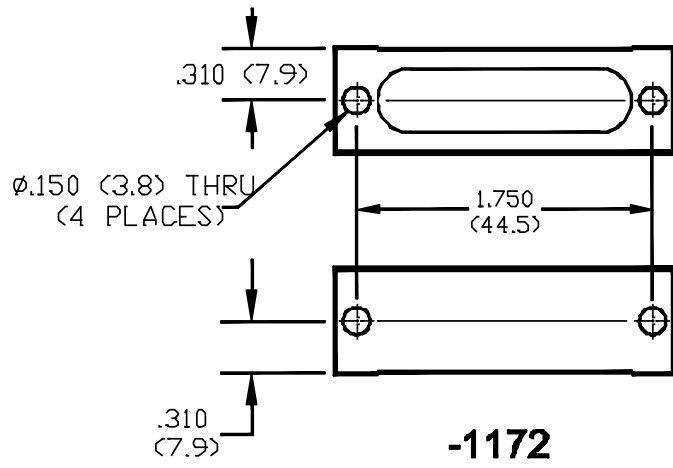
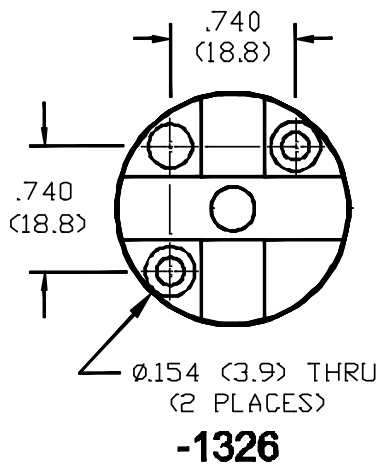

Dimensions in Inches (mm)

FIGURE 3

Mounting Hole Patterns for Miniature Tilt Sensors

Physical Characteristics

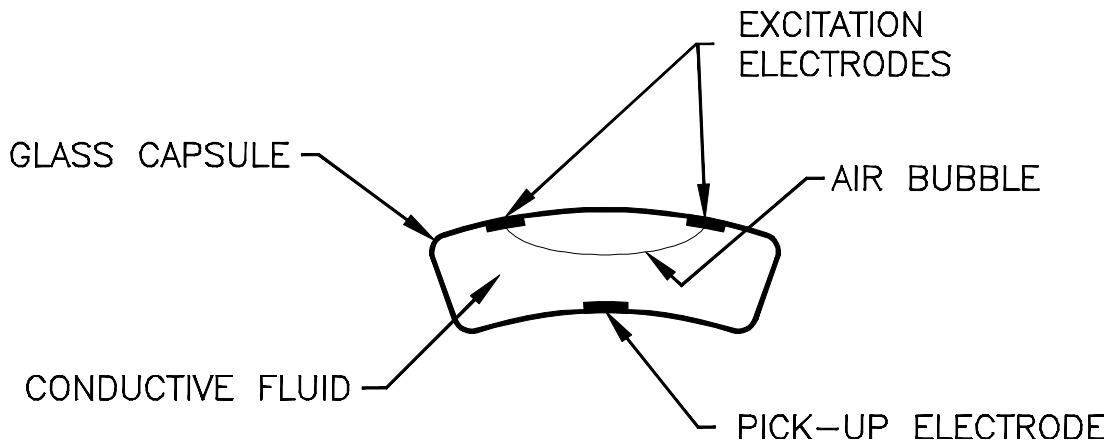

FIGURE 4

Electrolevel Physical Characteristics

Electrical Characteristics

Sensor behaves as variable resistor

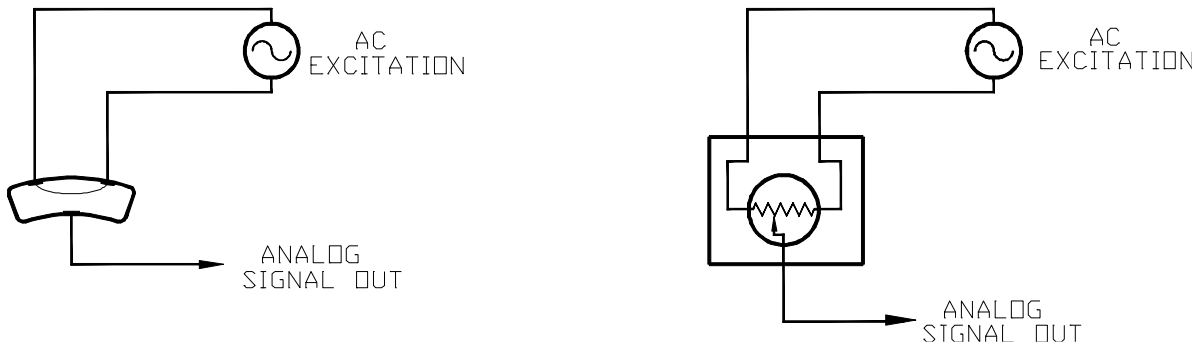

FIGURE 5

Electrolevel Electrical Characteristics

STANDARD TEST CIRCUIT (A.C. BRIDGE)

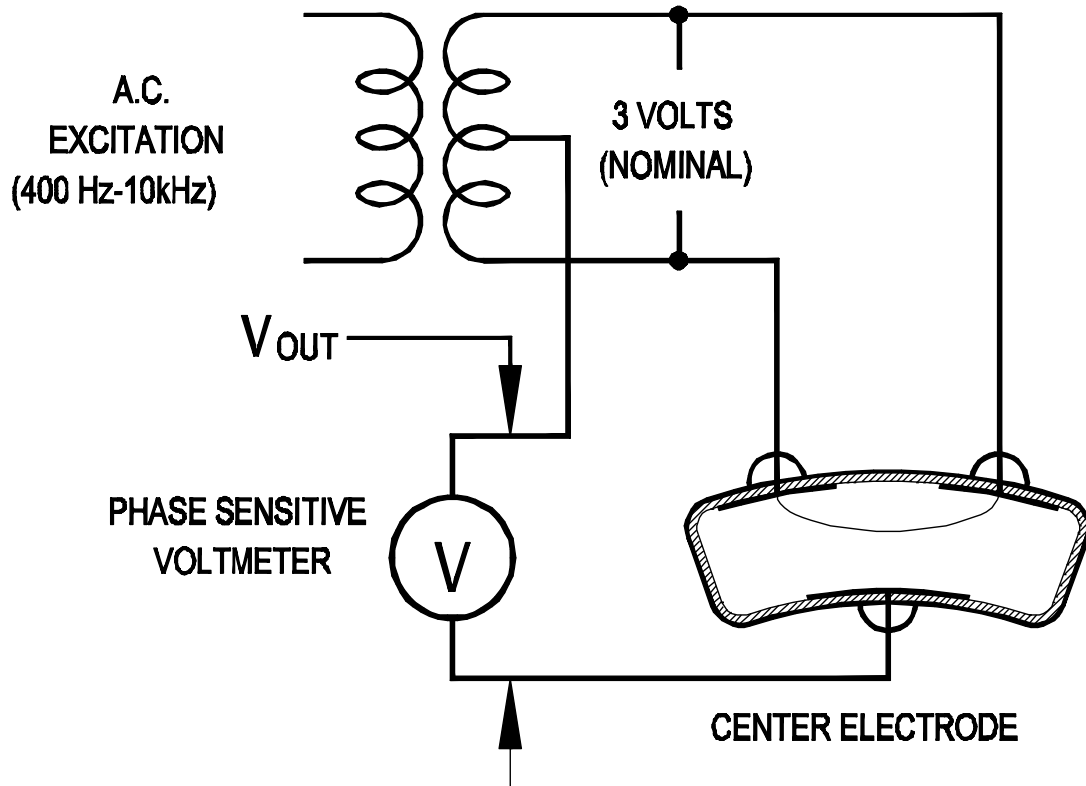

FIGURE 6

Basic Signal Conditioning: One Electrolytic Sensor

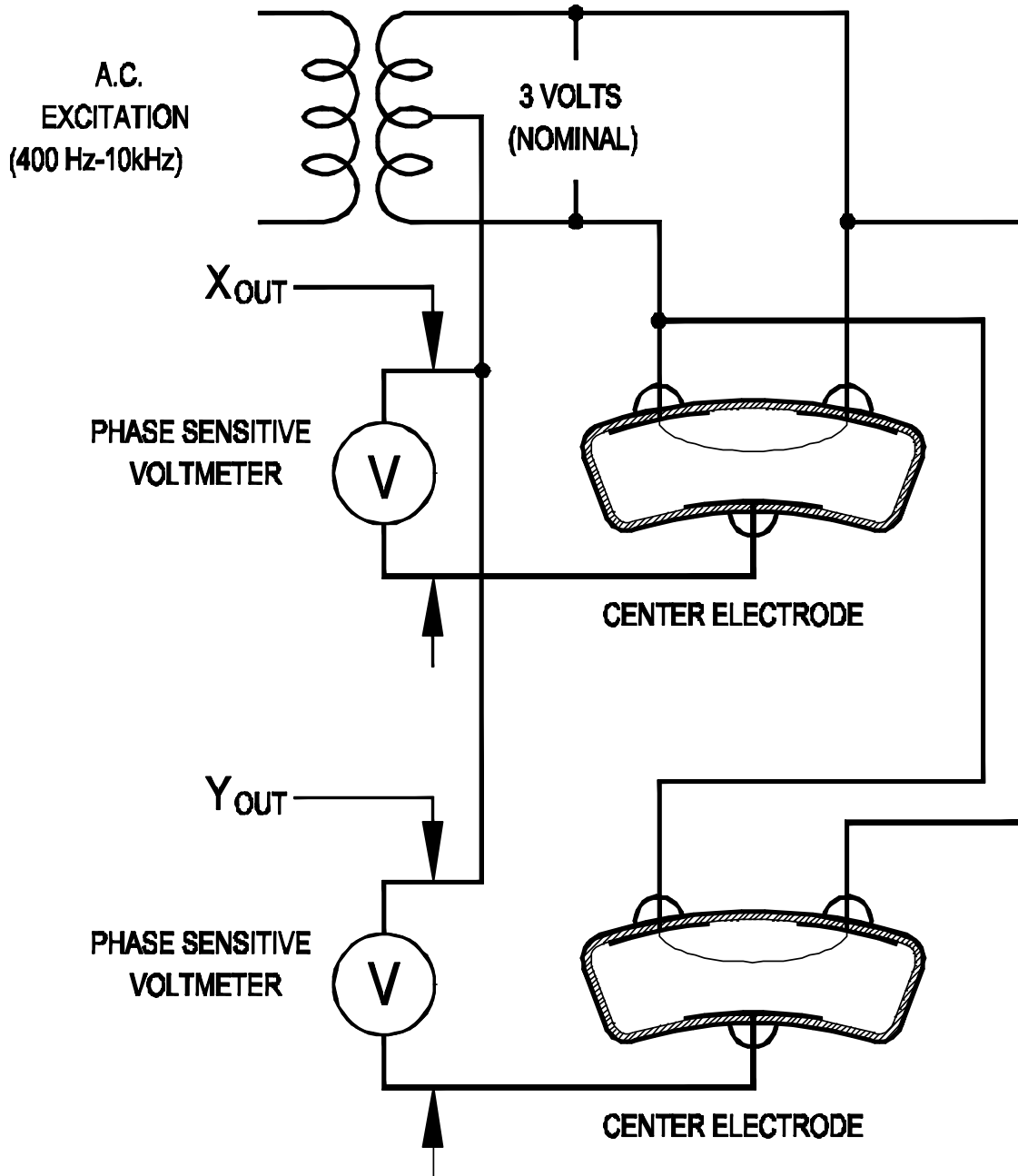

FIGURE 7

Basic Signal Conditioning: Two Electrolytic Sensor

APPENDIX A - Warranty and Assistance

Jewell Instruments Tiltmeters and accessories are warranted against defects in materials and workmanship for one year from the date of shipment from our factory. We will repair or replace (at our option) products that prove to be defective during the warranty period, provided they are returned prepaid to Jewell Instruments LLC. No other warranty is express or implied. The warranty is void if the equipment is subjected to lightning strikes, or other large potential gradients, or if it is otherwise operated in a manner contrary to its specified use. After the expiration of the warranty, Jewell will repair the equipment at its factory for parts and labor charges. Products returned after warranty expiration should be accompanied by a purchase order to cover repair costs and an RMA number obtainable in advance by calling Jewell.

The remedies provided herein are the buyer's sole and exclusive remedies. JEWELL SHALL NOT BE LIABLE FOR ANY DIRECT, INDIRECT, SPECIAL, INCIDENTAL, OR CONSEQUENTIAL DAMAGES, WHETHER BASED ON CONTRACT, TORT, OR ANY OTHER LEGAL THEORY.

APPENDIX B - Wiring Specifications

Transducer Wire Color Coding

The tilt sensors shipped with this user's manual are labeled as follows (Pin 1 on the signal conditioning cards are always +):

| 755 | | 756 | | 755/756 Kapton | |
|----------|------------|----------|------------|----------------|------------|
| Function | Wire Color | Function | Wire Color | Function | Wire Color |
| + | White | + | Green | + | + |
| E | Yellow | E | Yellow | E | E |
| - | Brown | - | Orange | - | - |

| Sensor Serial No. _____ | | Sensor Serial No. _____ | | Temperature Sensor | |
|-------------------------|------------|-------------------------|------------|--------------------|------------|
| Function | Wire Color | Function | Wire Color | Function | Wire Color |
| + | | + | | T1 | Red |
| E | | E | | T2 | Orange |
| - | | - | | T3 | Yellow |

In this nomenclature the (+) and (-) wires correspond to the two top, or excitation, electrodes of the tilt transducer, as shown in Figures 5, 6, 7, and 8 of this manual. The (+) electrode is on the +X or +Y side of the transducer. The (E) wire corresponds to the center, or pick-up, electrode of the transducer.

In units that include a temperature sensor, the temperature sensor is an LM35C made by the National Semiconductor Corporation. The scale factor of the temperature sensor output is 0.1°C/mV. Specifications and wiring instructions for the LM35C are explained in Appendix C. Appendix C is taken from the "Data Acquisition, Linear Devices Databook" published by National Semiconductor Corporation, Santa Clara, California, which also contains other information about this sensor. The conversion between the Appendix C nomenclature and our nomenclature is as follows:

T1 = +Vs
 T2 = Vout
 T3 = GND

APPENDIX B - Custom Specifications (For your Equipment)

Signal Conditioning Unit Serial No.: _____

Transducer Wire Colors

The wire colors of the tilt and temperature transducers shipped with this unit correspond to the following functions (see Section 2.1):

| Transducer Ser. No. _____ | | Transducer Ser. No. _____ | | Transducer Ser. No. _____ | |
|---------------------------|------------|---------------------------|------------|---------------------------|------------|
| Function | Wire Color | Function | Wire Color | Function | Wire Color |
| + | | + | | + | |
| E | | E | | E | |
| - | | - | | - | |

| Transducer Ser. No. _____ | | Transducer Ser. No. _____ | | Temperature Sensor | |
|---------------------------|------------|---------------------------|------------|--------------------|------------|
| Function | Wire Color | Function | Wire Color | Function | Wire Color |
| + | | + | | T1 | Red |
| E | | E | | T2 | Orange |
| - | | - | | T3 | Yellow |

Filters

Your SCU has two single-pole RC low-pass filters (integrators) selected by the FILTER switch on the front panel. The time constant (τ) for each filter setting is listed below. After an instantaneous change in tilt, the output signal settles to 90% of this value after three-time constants, and to 98% of this value after four-time constants. The corner or cutoff frequency f_c is defined as the frequency at which signal attenuation is 3 db. Filter roll-off above the corner frequency is constant at 6 dB per octave (20 dB per decade). Corner frequency can be calculated as: $f_c = 1/(2\pi\tau)$

τ values for filter settings:

ON: _____ seconds

OFF: _____ seconds

Scale Factors

Your Signal Conditioning Unit has been calibrated for operation with the tilt transducers listed above. However, it will operate any Jewell Instruments tilt transducer. If you purchase new tilt transducers for use with this SCU, they should be calibrated with this unit prior to use.

LM35

Precision Centigrade Temperature Sensors

General Description

The LM35 series are precision integrated-circuit temperature sensors, whose output voltage is linearly proportional to the Celsius (Centigrade) temperature. The LM35 thus has an advantage over linear temperature sensors calibrated in ° Kelvin, as the user is not required to subtract a large constant voltage from its output to obtain convenient Centigrade scaling. The LM35 does not require any external calibration or trimming to provide typical accuracies of $\pm 1/4^\circ\text{C}$ at room temperature and $\pm 3/4^\circ\text{C}$ over a full -55 to $+150^\circ\text{C}$ temperature range. Low cost is assured by trimming and calibration at the wafer level. The LM35's low output impedance, linear output, and precise inherent calibration make interfacing to readout or control circuitry especially easy. It can be used with single power supplies, or with plus and minus supplies. As it draws only $60\ \mu\text{A}$ from its supply, it has very low self-heating, less than 0.1°C in still air. The LM35 is rated to operate over a -55° to $+150^\circ\text{C}$ temperature range, while the LM35C is rated for a -40° to $+110^\circ\text{C}$ range (-10° with improved accuracy). The LM35 series is available pack-

aged in hermetic TO-46 transistor packages, while the LM35C, LM35CA, and LM35D are also available in the plastic TO-92 transistor package. The LM35D is also available in an 8-lead surface mount small outline package and a plastic TO-220 package.

Features

- Calibrated directly in ° Celsius (Centigrade)
- Linear $+ 10.0\ \text{mV}/^\circ\text{C}$ scale factor
- 0.5°C accuracy guaranteeable (at $+25^\circ\text{C}$)
- Rated for full -55° to $+150^\circ\text{C}$ range
- Suitable for remote applications
- Low cost due to wafer-level trimming
- Operates from 4 to 30 volts
- Less than $60\ \mu\text{A}$ current drain
- Low self-heating, 0.08°C in still air
- Nonlinearity only $\pm 1/4^\circ\text{C}$ typical
- Low impedance output, $0.1\ \Omega$ for $1\ \text{mA}$ load

Connection Diagrams

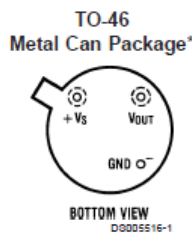

*Case is connected to negative pin (GND)
Order Number LM35H, LM35AH, LM35CH, LM35CAH or LM35DH
See NS Package Number H03H



Order Number LM35CZ,
LM35CAZ or LM35DZ
See NS Package Number Z03A

Typical Applications

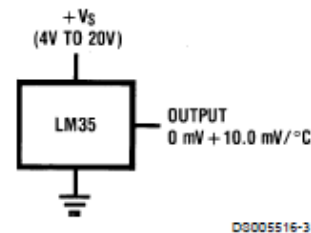
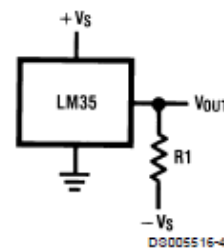

FIGURE 1. Basic Centigrade Temperature Sensor ($+2^\circ\text{C}$ to $+150^\circ\text{C}$)



Choose $R_1 = -V_S/50\ \mu\text{A}$
 $V_{\text{OUT}} = +1,500\ \text{mV}$ at $+150^\circ\text{C}$
 $= +250\ \text{mV}$ at $+25^\circ\text{C}$
 $= -550\ \text{mV}$ at -55°C

FIGURE 2. Full-Range Centigrade Temperature Sensor

APPENDIX C - Revision Table

| REV. | PAGE NOS. | ECN NO. | DESCRIPTION OF CHANGE | DATE |
|-------------|---------------------|----------------|---|-------------|
| D | ALL | 25055 | "Jewell" was "Applied Geomechanics" Added Appendix C for revision record | 2/05/13 |
| E | 2,3,5,8, 12 & 13 | 26587 | Deleted models 757 & 758 tiltmeter refs. | 8/19/14 |
| F | 7 | 27086 | Added NOTE to Tables 1 and 2 | 4/13/15 |
| G | 9 | 28363 | Added 1150-06 vacuum puck picture to Figure 2 | 7/25/17 |
| H | All | 28224 | Remove Serial No from 1 st page | 05/31/18 |
| J | Page 5 | 31469 | Updated temp range operational & storage) | 10/29/2024 |
| K | All Pages | X | Updated photos and added wire colors to pin out. | 10/25/25 |
| | | | | |
| | | | | |
| | | | | |
| | | | | |
| | | | | |
| | | | | |
| | | | | |